

蚀刻框架产品 saw type

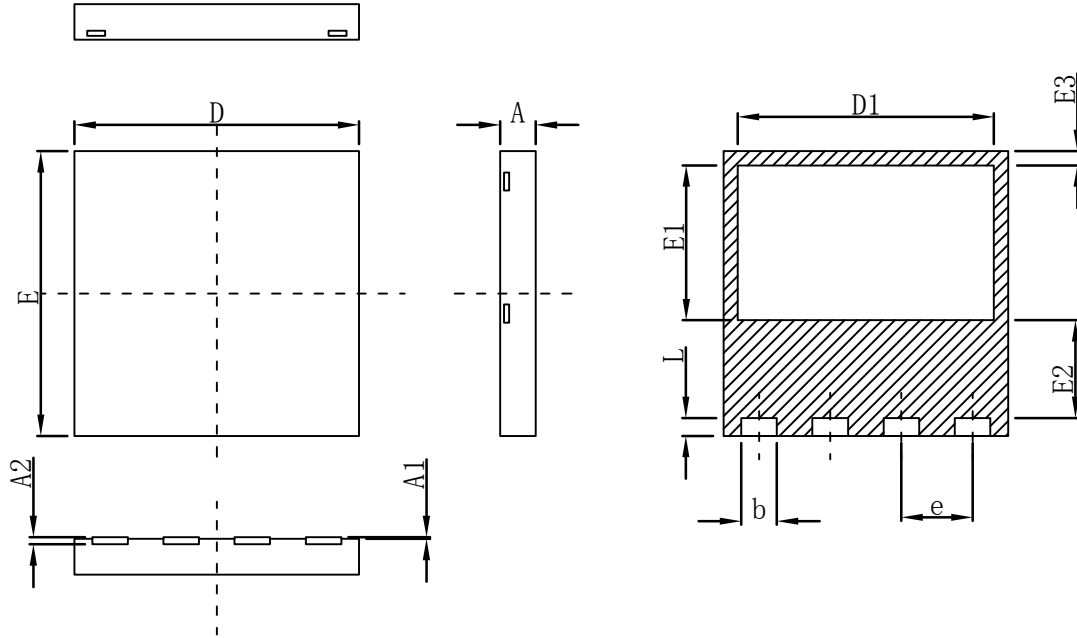

symbol	Dimensions In Millimeters			Dimensions In Inches		
	Min	Nom	Max	Min	Nom	Max
A	0.70	0.75	0.80	0.028	0.030	0.032
A1	0.00	0.025	0.05	0.000	0.001	0.002
A2	0.10	0.20	0.30	0.004	0.008	0.012
b	0.90	1.00	1.10	0.035	0.039	0.043
D	7.90	8.00	8.10	0.311	0.315	0.319
D1	7.10	7.20	7.30	0.280	0.284	0.287
E	7.90	8.00	8.10	0.311	0.315	0.319
E1	4.25	4.35	4.45	0.167	0.171	0.175
E2	2.65	2.75	2.85	0.104	0.108	0.112
E3	0.30	0.40	0.50	0.012	0.016	0.020
L	0.40	0.50	0.60	0.016	0.020	0.024
e	2.00 BSC			0.079 BSC		

FSMC

图名 NAME	WDFN8080-4	图号 DWG. NO.	DD0090	SH 1 OF 1
材质 MATERIAL	A194	REV.	A	
单位 UNITS	mm [INCH]	核准 APPROVE	审核 CHECKED	制图 DRAWN
日期 DATE	2020.10.14			 第三角法
比例 SCALE	N. T. S.			